

THE POWER OF

REDARC[®]

RS Series 12V & 24V Inverters
Double Insulated

(700/1000/1500/2000/3000W models)

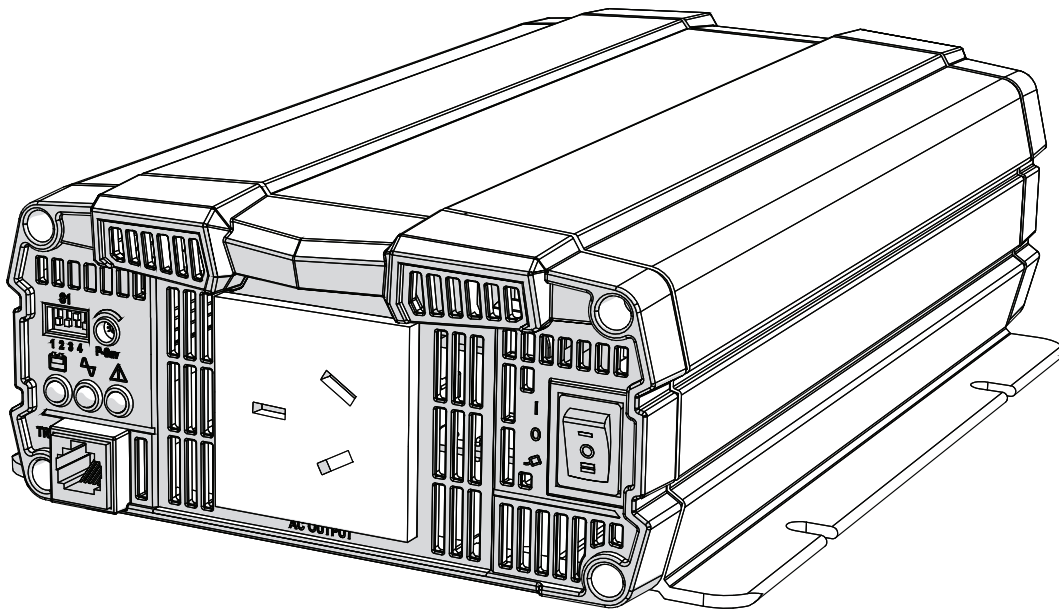

RS SERIES INVERTERS

REDARC Pure Sine Wave Inverters produce a pure sine wave output. This means that the power output from a REDARC Pure Sine Wave Inverter is not only the same as the mains supply, it's often better!

WARNINGS & SAFETY INSTRUCTIONS

SAVE THESE INSTRUCTIONS - This manual contains **IMPORTANT SAFETY INSTRUCTIONS** for the REDARC RS series Pure Sine Wave Inverters.

DO NOT OPERATE THE INVERTER UNLESS YOU HAVE READ AND UNDERSTOOD THIS MANUAL AND THE INVERTER IS INSTALLED AS PER THESE INSTALLATION INSTRUCTIONS. REDARC RECOMMENDS THAT THE INVERTER BE INSTALLED BY A SUITABLY QUALIFIED PERSON.

⚠ WARNING

- 1. RISK OF ELECTRICAL SHOCK. DO NOT DISASSEMBLE THE INVERTER - THE INTERNAL CIRCUITRY CONTAINS HAZARDOUS VOLTAGES. ATTEMPTING TO SERVICE THE UNIT YOURSELF MAY RESULT IN ELECTRIC SHOCK OR FIRE AND WILL VOID THE UNIT WARRANTY.**
- 2. RISK OF ELECTRICAL SHOCK. DO NOT EXPOSE THE INVERTER TO RAIN, SNOW, SPRAY, BILGE OR DUST. DOING SO MAY RESULT IN DAMAGE TO THE INVERTER OR OTHER APPLIANCES INSTALLED IN THE SYSTEM OR RESULT IN ELECTRIC SHOCK OR FIRE.**
- 3. RISK OF ELECTRICAL SHOCK. OPERATION OF THE INVERTER WITHOUT A PROPER GROUND CONNECTION MAY RESULT IN AN ELECTRICAL SAFETY HAZARD. ENSURE PROPER GROUND CONNECTION IS MADE DURING INSTALLATION. FOR FIXED AND/OR TRANSPORTABLE (VEHICLE) INSTALLATIONS, INSTALL ACCORDING TO APPROPRIATE AS/NZS STANDARD.**
- 4. RISK OF ELECTRICAL SHOCK. BEFORE PROCEEDING, CAREFULLY CHECK THAT THE INVERTER IS NOT CONNECTED TO ANY BATTERIES AND THAT ALL WIRING IS DISCONNECTED FROM ANY ELECTRICAL SOURCES.**
- 5. DO NOT CONNECT THE OUTPUT TERMINALS OF THE INVERTER TO AN INCOMING AC SOURCE.**

⚠ CAUTION

1. This appliance is not intended for use by persons (including children) with reduced physical, sensory or mental capabilities, or lack of experience and knowledge, unless they are supervised or have been instructed on how to use the appliance by a person responsible for their safety. Children should be supervised to ensure that they do not play with the appliance.
2. Do not operate the inverter with damaged or substandard wiring. Selecting the wrong cable or fuse size could result in harm to the installer or user and/or damage to the inverter or other appliances installed in the system. The installer is responsible for ensuring that the correct cable and fuse sizes are used when installing this inverter. Refer to section 2.2.4 for more information.
3. Ensure that all the DC connections are tight - torque to 11.7-13Nm (9-10 ft-lbs). Loose connections could result in overheating and can be a potential hazard.
4. Some components in the inverter can cause arcs and sparks. Do not put batteries, flammable materials, or anything that should be ignition-protected around the inverter. Doing so may result in fire or explosion.

WARNINGS AND SAFETY INSTRUCTIONS

5. Be extra cautious so as to reduce the risk of dropping a metal tool onto a vehicle battery. Doing so might cause the battery to spark or might short-circuit the battery or other electrical parts that may cause an explosion.
6. Remove personal metal items such as rings, bracelets, necklaces, and watches when working with a battery. A battery can produce a short-circuit current high enough to weld a ring or the like to metal, causing a severe burn.
7. If battery acid contacts your skin or clothing, remove the affected clothing and wash the affected area of your skin immediately with soap and water. If battery acid enters your eye, immediately flood the eye with running cold water for at least 10 minutes and seek medical assistance immediately.
8. NEVER smoke or allow a spark or flame in vicinity of battery. This may cause the battery to explode.
9. Batteries are capable of providing very large currents in the case of a short circuit. A fuse must be installed on the positive supply cable as close as practical to the battery. Failure to do so provides inadequate protection against fire in the case of a short circuit. Only use high quality copper cable and keep the cable length short, refer to section 2.2.4 for more information.

NOTICE

1. Upon receipt, examine the box for damage. If you have found any damage on the box please notify the company you purchased this unit from.
2. Install the inverter in a well-ventilated area with reasonable clearance. Do not install the inverter in a zero-clearance compartment or obstruct the ventilation openings. Doing so may result in the inverter overheating and ultimately damage the inverter.
3. Reverse Polarity connection will blow the internal fuse and may damage the inverter permanently and will void warranty.
4. Do not operate appliances that may feed power back into the inverter. Damage to the inverter may occur as a result.
5. This inverter is isolated in accordance with AS/NZS 4763 and does not normally require RCD protection. The AC output active and neutral are isolated from the DC Input Supply and Chassis Earth by double insulation. The output earth pin is not connected to ground, it is floating.
6. If for any reason an RCD is required it should be fitted by a licensed electrician. External connection of neutral and chassis earth should be determined as appropriate or not by the licensed electrician on the specific case by case basis.
7. Ensure that the frequency output of the inverter matches the frequency requirements of all attached to the inverter. Attempting to use appliances that requires an AC frequency different to the inverter output may result in damage to your appliances.
8. All RS Series Inverters are suitable for indoor use only.

CONTENTS

Table of Contents	Page
Warnings and Safety Instructions	01
Contents	02
1 Introduction	04
1. Quick Start Guide	04
2. Specifications	05
3. Voltage and temperature performance	10
4. Dimensions	11
2 User Guide	12
1. Front Panel Operations	12
1. Main Switch	13
2. Indicator LED	13
3. Function Switch	15
4. Power Saving Load Adjustment	16
5. TRC Port (RJ45)	16
6. AC Output Interface	17
2. Rear Panel Operations	18
1. Remote Port (RJ11)	19
2. Remote Control Green Terminal	19
3. Chassis Ground	20
4. DC Input Connection	20
3 Installation	22
1. Mounting	22
2. Ventilation Fan	22
3. DC Wiring Connections	23
4. AC Safety Grounding	25
5. Maintenance	25
4 Two Year Product Warranty	26

1 INTRODUCTION

1.1 Quick Start Guide

1 Ensure no loads are connected to the Inverters AC Output.

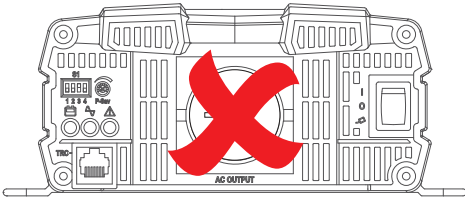

Ensure all Loads are Disconnected

2 Ensure that the Inverter Main Switch is set to the 'OFF' position.

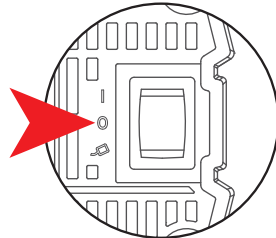

Set Main Switch to 'OFF'

3 Connect the DC cables to the Inverters DC Input Terminals.

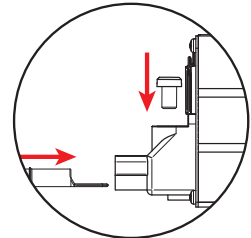

Connect DC Cables

4 Ensure that the cable is of adequate size and is protected by the correct sized fuse.

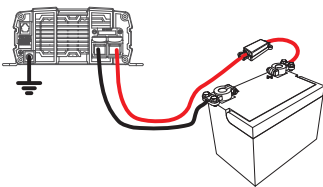

Check cable and fuse size
(Refer section 2.2.4)

5 Connect Chassis Ground Terminal to Negative Input Terminal

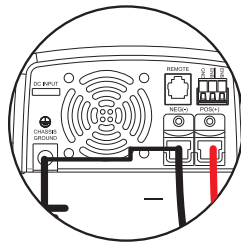

Ensure Unit is Grounded

6 Switch the Inverter Main Switch to the 'ON' position.

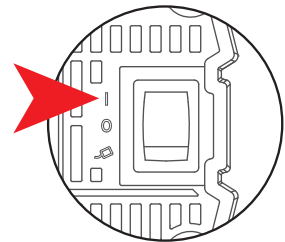

Set Main Switch to 'ON'

7 All LEDs will glow 'Green'.

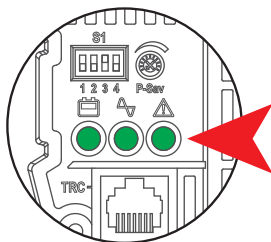

LEDs will glow 'Green'

8 If both LED's are 'Green' switch unit off & connect loads to the Inverter AC Output.

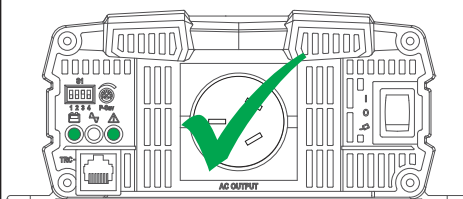

Switch OFF and connect AC loads

9 If the Inverter Status LED is not 'Green' please refer to section 2.1.2.3.

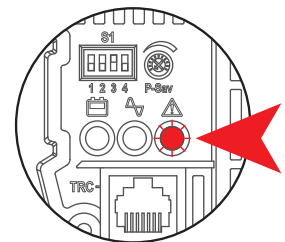

Refer to section 2.1.2.3

1 INTRODUCTION

1.2 Specifications

		R-12-700RS2	R-24-700RS2
Input Characteristics	Type	Isolated	
	Voltage	12VDC	24VDC
	Max. Rated Input Current	83A	42A
	Over-Voltage Protection	16.5 ± 0.3VDC	33 ± 0.5VDC
	Under-Voltage Protection	10.5 ± 0.3VDC	21 ± 0.5VDC
	Voltage Range	10.5~16.5VDC	21~33VDC
	No Load Current	<1.5A @ 12VDC	<0.8A @ 24VDC
	Power Saving Mode	<0.1A @ 12VDC	<0.06A @ 24VDC
Output Characteristics	Continuous Output Power	700VA (± 3%)	
	Maximum output Power (1 min)	> 700 VA~ 810 VA (100%~115%)	
	Surge Power (1 sec)	<1230VA	
	Frequency	50/60Hz ± 0.5% (Dip Switch Selectable)	
	Output Voltage	200/220/230/240 VAC ± 3% (Dip Switch Selectable)	
	Efficiency Max	88%	89%
	Short-Circuit Protection	1 Sec Shutdown	
	Output Waveform	Pure Sine Wave (THD < 5% @ Normal Load)	
Signal and Control	Remote Controller Panel Input	REMOTE-RS (optional)	
	LED Indicator	Red / Orange / Green LED	
	Dry Contact Terminal	By a relay	
	Remote Control Terminal	6-port Green terminal (for inverter ON/OFF)	
Protection	Input Protection	Over / Under Voltage	
	AC Output Protection	Short-Circuit, Overload	
	Others	Over / Under Temperature Protection (by Heat sink Temperature +80°C /-20°C)	
Environment	Operating Temp.	-20°C~40°C (Derates to 60°C)	
	Storage Temp.	-30°C~70°C	
	Storage Temp. & Humidity	10~95% RH	
Safety and EMC	Safety Standards	Certified AS/NZS 4763	
	EMC Standards	Certified EN 55022; EN 55024; EN 61000-3-2, -3-3 EN 61000-4-2, 3, 4, 5, 6, 8, 11	
	E-mark	Certified CISPR 25; ISO 7637-2	
	Weight	2.6 KG	
	Cooling	Temperature & Load Controlled cooling Fan	

* this equipment has been tested and certified as an isolated inverter in accordance with AS/NZS 4763. It is double insulated to provide enhanced user safety.

1 INTRODUCTION

		R-12-1000RS2	R-24-1000RS2
Input Characteristics	Type	Isolated	
	Voltage	12VDC	24VDC
	Max. Rated Input Current	119A	60A
	Over-Voltage Protection	16.5 ± 0.3VDC	33 ± 0.5VDC
	Under-Voltage Protection	10.5 ± 0.3VDC	21 ± 0.5VDC
	Voltage Range	10.5~16.5VDC	21~33VDC
	No Load Current	<1.5A @ 12VDC	<0.8A @ 24VDC
	Power Saving Mode	<0.1A @ 12VDC	<0.06A @ 24VDC
Output Characteristics	Continuous Output Power	1000VA (± 3%)	
	Maximum output Power (1 min)	> 1000 VA~ 1150 VA (100%~115%)	
	Surge Power (1 sec)	<1750VA	
	Frequency	50/60Hz ± 0.5% (Dip Switch Selectable)	
	Output Voltage	200/220/230/240 VAC ± 3% (Dip Switch Selectable)	
	Efficiency Max	88%	89%
	Short-Circuit Protection	1 Sec Shutdown	
	Output Waveform	Pure Sine Wave (THD < 5% @ Normal Load)	
Signal and Control	Remote Controller Panel Input	REMOTE-RS (optional)	
	LED Indicator	Red / Orange / Green LED	
	Dry Contact Terminal	By a relay	
	Remote Control Terminal	6-port Green terminal (for inverter ON/OFF)	
Protection	Input Protection	Over / Under Voltage	
	AC Output Protection	Short-Circuit, Overload	
	Others	Over / Under Temperature Protection (by Heat sink Temperature +80°C /-20°C)	
Environment	Operating Temp.	-20°C~40°C (Derates to 60°C)	
	Storage Temp.	-30°C~70°C	
	Storage Temp. & Humidity	10~95% RH	
Safety and EMC	Safety Standards	Certified AS/NZS 4763	
	EMC Standards	Certified EN 55022; EN 55024; EN 61000-3-2, -3-3 EN 61000-4-2, 3, 4, 5, 6, 8, 11	
	E-mark	Certified CISPR 25; ISO 7637-2	
Weight		3.26 KG	
Cooling		Temperature & Load Controlled cooling Fan	

* this equipment has been tested and certified as an isolated inverter in accordance with AS/NZS 4763. It is double insulated to provide enhanced user safety.

1 INTRODUCTION

		R-12-1500RS2	R-24-1500RS2
Input Characteristics	Type	Isolated	
	Voltage	12VDC	24VDC
	Max. Rated Input Current	179A	89A
	Over-Voltage Protection	16.5 ± 0.3VDC	33 ± 0.5VDC
	Under-Voltage Protection	10.5 ± 0.3VDC	21 ± 0.5VDC
	Voltage Range	10.5~16.5VDC	21~33VDC
	No Load Current	<1.8A @ 12VDC	<0.9A @ 24VDC
	Power Saving Mode	<0.1A @ 12VDC	<0.05A @ 24VDC
Output Characteristics	Continuous Output Power	1500VA (± 3%)	
	Maximum output Power (1 min)	> 1500 VA~ 1730 VA (100%~115%)	
	Surge Power (1 sec)	<2650VA	
	Frequency	50/60Hz ± 0.5% (Dip Switch Selectable)	
	Output Voltage	200/220/230/240 VAC ± 3% (Dip Switch Selectable)	
	Efficiency Max	88%	89%
	Short-Circuit Protection	1 Sec Shutdown	
	Output Waveform	Pure Sine Wave (THD < 5% @ Normal Load)	
Signal and Control	Remote Controller Panel Input	REMOTE-RS (optional)	
	LED Indicator	Red / Orange / Green LED	
	Dry Contact Terminal	By a relay	
	Remote Control Terminal	6-port Green terminal (for inverter ON/OFF)	
Protection	Input Protection	Over / Under Voltage	
	AC Output Protection	Short-Circuit, Overload	
	Others	Over / Under Temperature Protection (by Heat sink Temperature +80°C /-20°C)	
Environment	Operating Temp.	-20°C~40°C (Derates to 60°C)	
	Storage Temp.	-30°C~70°C	
	Storage Temp. & Humidity	10~95% RH	
Safety and EMC	Safety Standards	Certified AS/NZS 4763	
	EMC Standards	Certified EN 55022; EN 55024; EN 61000-3-2, -3-3 EN 61000-4-2, 3, 4, 5, 6, 8, 11	
	E-mark	Certified CISPR 25; ISO 7637-2	
Weight		4.14 KG	
Cooling		Temperature & Load Controlled cooling Fan	

* this equipment has been tested and certified as an isolated inverter in accordance with AS/NZS 4763. It is double insulated to provide enhanced user safety.

1 INTRODUCTION

		R-12-2000RS2	R-24-2000RS2
Input Characteristics	Type	Isolated	
	Voltage	12VDC	24VDC
	Max. Rated Input Current	238A	119A
	Over-Voltage Protection	16.5 ± 0.3VDC	33 ± 0.5VDC
	Under-Voltage Protection	10.5 ± 0.3VDC	21 ± 0.5VDC
	Voltage Range	10.5~16.5VDC	21~33VDC
	No Load Current	<1.8A @ 12VDC	<0.9A @ 24VDC
	Power Saving Mode	<0.1A @ 12VDC	<0.05A @ 24VDC
Output Characteristics	Continuous Output Power	2000VA (± 3%)	
	Maximum output Power (1 min)	> 2000 VA~ 2300 VA (100%~115%)	
	Surge Power (1 sec)	<3500VA	
	Frequency	50/60Hz ± 0.5% (Dip Switch Selectable)	
	Output Voltage	200/220/230/240 VAC ± 3% (Dip Switch Selectable)	
	Efficiency Max	88%	89%
	Short-Circuit Protection	1 Sec Shutdown	
	Output Waveform	Pure Sine Wave (THD < 5% @ Normal Load)	
Signal and Control	Remote Controller Panel Input	REMOTE-RS (optional)	
	LED Indicator	Red / Orange / Green LED	
	Dry Contact Terminal	By a relay	
	Remote Control Terminal	6-port Green terminal (for inverter ON/OFF)	
Protection	Input Protection	Over / Under Voltage	
	AC Output Protection	Short-Circuit, Overload	
	Others	Over / Under Temperature Protection (by Heat sink Temperature +80°C /-20°C)	
Environment	Operating Temp.	-20°C~40°C (Derates to 60°C)	
	Storage Temp.	-30°C~70°C	
	Storage Temp. & Humidity	10~95% RH	
Safety and EMC	Safety Standards	Certified AS/NZS 4763	
	EMC Standards	Certified EN 55022; EN 55024; EN 61000-3-2, -3-3 EN 61000-4-2, 3, 4, 5, 6, 8, 11	
	E-mark	Certified CISPR 25; ISO 7637-2	
Weight		5.24 KG	
Cooling		Temperature & Load Controlled cooling Fan	

* this equipment has been tested and certified as an isolated inverter in accordance with AS/NZS 4763. It is double insulated to provide enhanced user safety.

1 INTRODUCTION

		R-12-3000RS2	R-24-3000RS2
Input Characteristics	Type	Isolated	
	Voltage	12VDC	24VDC
	Max. Rated Input Current	375A	179A
	Over-Voltage Protection	16.5 ± 0.3VDC	33 ± 0.5VDC
	Under-Voltage Protection	10.5 ± 0.3VDC	21 ± 0.5VDC
	Voltage Range	10.5~16.5VDC	21~33VDC
	No Load Current	<3.8A @ 12VDC	<1.9A @ 24VDC
	Power Saving Mode	<0.4A @ 12VDC	<0.2A @ 24VDC
Output Characteristics	Continuous Output Power	3000VA (± 3%)	
	Maximum output Power (1 min)	> 3000 VA~ 3450 VA (100%~115%)	
	Surge Power (1 sec)	<6000VA	
	Frequency	50/60Hz ± 0.5% (Dip Switch Selectable)	
	Output Voltage	200/220/230/240 VAC ± 3% (Dip Switch Selectable)	
	Efficiency Max	89%	89%
	Short-Circuit Protection	1 Sec Shutdown	
	Output Waveform	Pure Sine Wave (THD < 5% @ Normal Load)	
Signal and Control	Remote Controller Panel Input	REMOTE-RS (optional)	
	LED Indicator	Red / Orange / Green LED	
	Dry Contact Terminal	By a relay	
	Remote Control Terminal	6-port Green terminal (for inverter ON/OFF)	
Protection	Input Protection	Over / Under Voltage	
	AC Output Protection	Short-Circuit, Overload	
	Others	Over / Under Temperature Protection (by Heat sink Temperature +80°C /-20°C)	
Environment	Operating Temp.	-20°C~40°C (Derates to 60°C)	
	Storage Temp.	-30°C~70°C	
	Storage Temp. & Humidity	10~95% RH	
Safety and EMC	Safety Standards	Certified AS/NZS 4763	
	EMC Standards	Certified EN 55022; EN 55024; EN 61000-3-2, -3-3 EN 61000-4-2, 3, 4, 5, 6, 8, 11	
	E-mark	Certified CISPR 25; ISO 7637-2	
Weight		8.2 KG	
Cooling		Temperature & Load Controlled cooling Fan	

* this equipment has been tested and certified as an isolated inverter in accordance with AS/NZS 4763. It is double insulated to provide enhanced user safety.

1 INTRODUCTION

1.3 Voltage and Temperature Performance

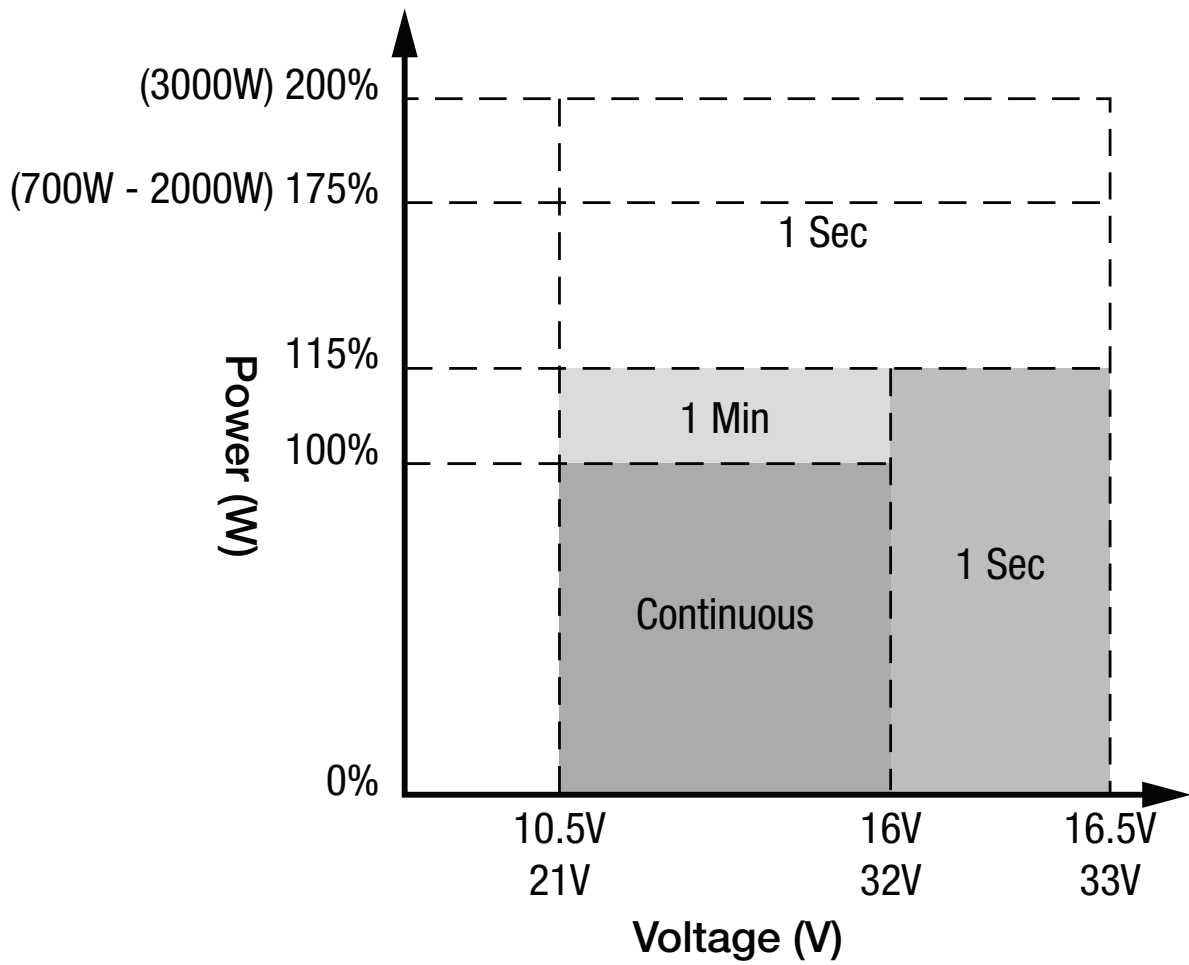

700W - 3000W

Figure 1.3.1 - Input Voltage vs. Output Power

1 INTRODUCTION

1.4 Dimensions

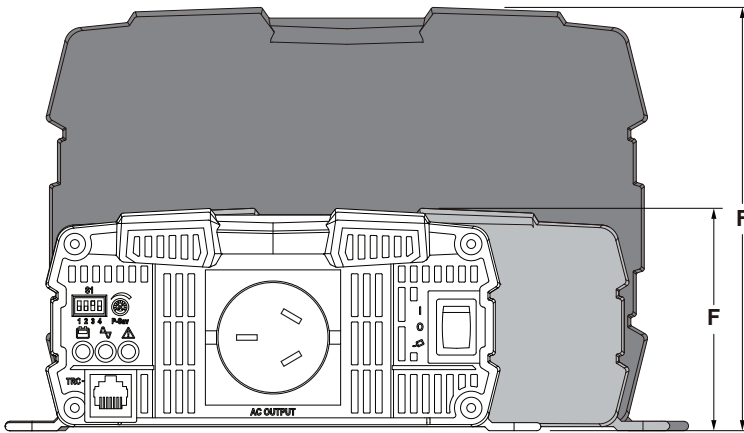
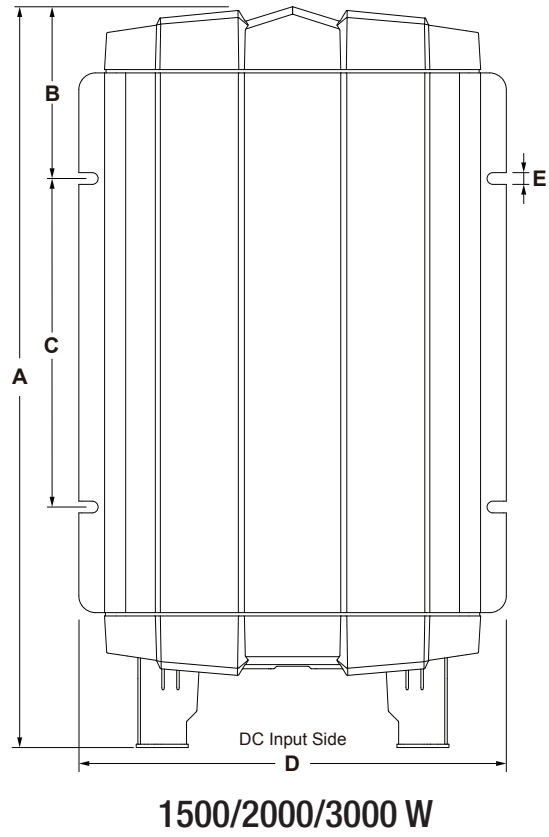
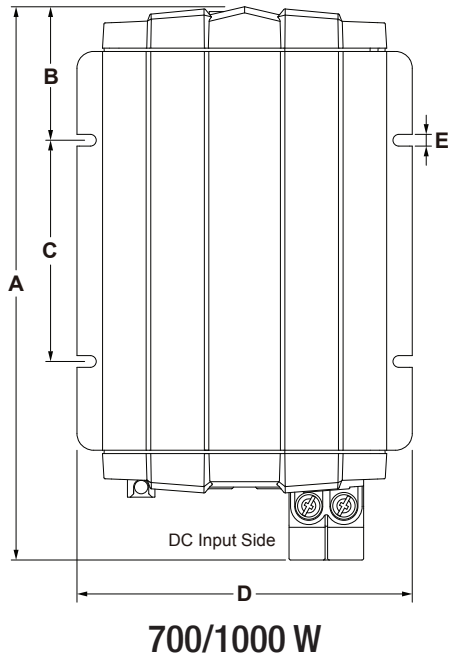

	A (mm)	B (mm)	C (mm)	D (mm)	E (mm)	F(mm)
700W	330	80	132	200	7.0	83
1000W	372	69	196	200	7.0	83
1500W	421	92	196	248	7.0	83
2000W	443	103	196	248	7.0	83
3000W	442	103	196	255	7.0	158

⚠ WARNING

RISK OF ELECTRICAL SHOCK. DO NOT DISASSEMBLE THE INVERTER - THE INTERNAL CIRCUITRY CONTAINS HAZARDOUS VOLTAGES. ATTEMPTING TO SERVICE THE UNIT YOURSELF MAY RESULT IN ELECTRIC SHOCK OR FIRE AND WILL VOID THE UNIT WARRANTY.

2.1 Front Panel Operation

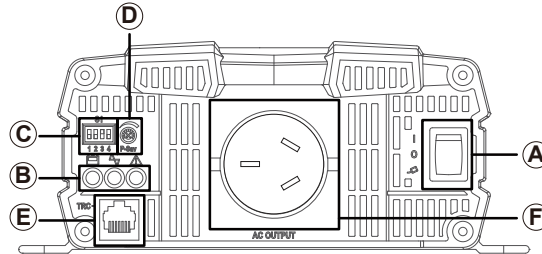

Figure 2.1.1 - 700/1000W Models

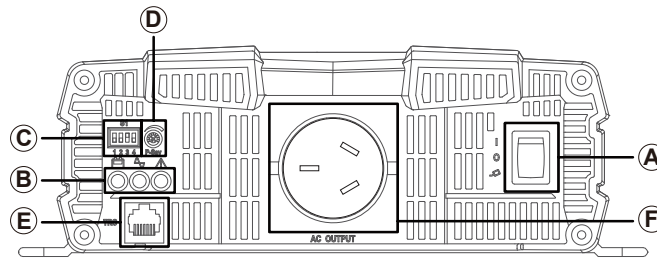

Figure 2.1.2 - 1500/2000W Models

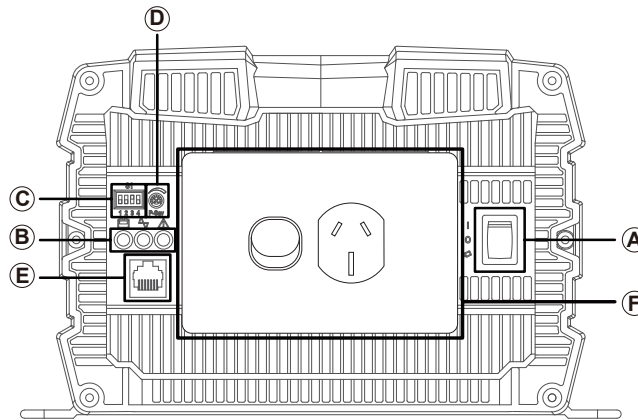

Figure 2.1.3 - 3000W Models

	700W	1000W	1500W	2000W	3000W
(A)	Main Switch				
(B)	Indicator LED				
(C)	Function Switch				
(D)	Power Save Adjustment				
(E)	TRC Port (RJ45)				
(F)	AC Output Interface				

2 USER GUIDE

2.1.1 Main Switch (A)

The 3 stage switch is for turning ON or OFF and selecting Remote mode

Set the power switch to the “ON” position. The LED will glow GREEN.

Set the power switch to the “OFF” position. The inverter will stop and all LEDs will turn off.

2.1.2 Indicator LED

(B)







2.1.2.1 Input Voltage Level

LED Status	12V Models	24V Models
Red	< 11.0V	< 22.0V
Orange	11.0 ~ 11.5V	22.0 ~ 23.0V
Green	11.5 ~ 15.0V	23.0 ~ 30.0V
Orange	15.0 ~ 15.5V	30.0 ~ 31.0V
Red	> 15.5V	> 31.0V

4.1.2.2 Output Load Level

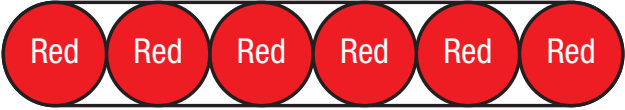
LED Status	Green	Orange	Red
700W	0 ~ 700 W	700 ~ 805 W	> 805 W
1000W	0 ~ 1000 W	1000 ~ 1150 W	> 1150 W
1500W	0 ~ 1500 W	1500 ~ 1725 W	> 1725 W
2000W	0 ~ 2000 W	2000 ~ 2300 W	> 2300 W
3000W	0 ~ 3000 W	3000 ~ 3450 W	> 3450 W

2.1.2.3 Inverter Status & fault conditions

Status	LED Status
Normal	 Green
Over Current Protection / Over Load Protection (AC output short and overload)	 Red
Under Voltage Protection (Input DC voltage under spec) Recovery Points: 12.5V (12V Models) / 25.0V (24V Models)	 Red Red Red
Over Voltage Protection (Input DC voltage over spec) Recovery Points: 14.5V (12V Models) / 29.0V (24V Models)	 Red Red Red Red Red Red
Device Startup process abnormal	 Orange
Under Temperature (Heatsink temperature under -20°C) Recovery point: > 0°C	 Orange Orange Orange Orange Orange Orange
Over Temperature (Heatsink temperature over 80°C) Recovery point: < 60°C	 Orange Orange Orange

2.1.3 Function Switch ©

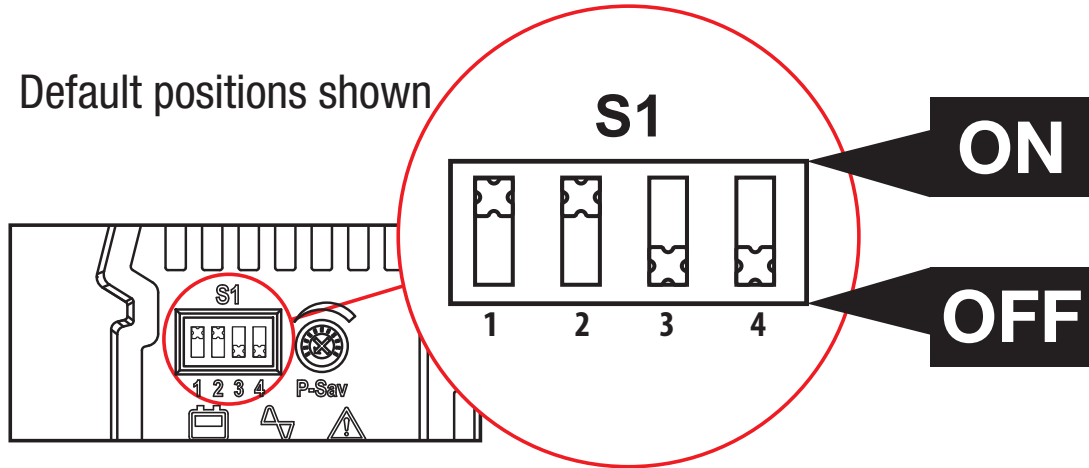

Figure 2.1.3.1 - Dip Switch ON/OFF Positions

2.1.3.2 Input Voltage Level

Dip Switch	Function
Switch 1	Output Voltage Select
Switch 2	
Switch 3	Frequency Select
Switch 4	Power Saving mode Select

2.1.3.3 Output Voltage Selection (Switches 1 & 2)

Output Voltage	Switch 1	Switch 2
200V	OFF	OFF
220V	ON	OFF
230V	OFF	ON
240V	ON	ON

2.1.3.4 Output Frequency (Switch 3)

Frequency (Hz)	Switch 3
50Hz	OFF
60Hz	ON

2.1.3.5 Power Saving mode Select

Power Saving Function	Switch 4
Power Saving OFF	OFF
Power Saving ON	ON

2.1.4 Power Saving Load Adjustment (D)

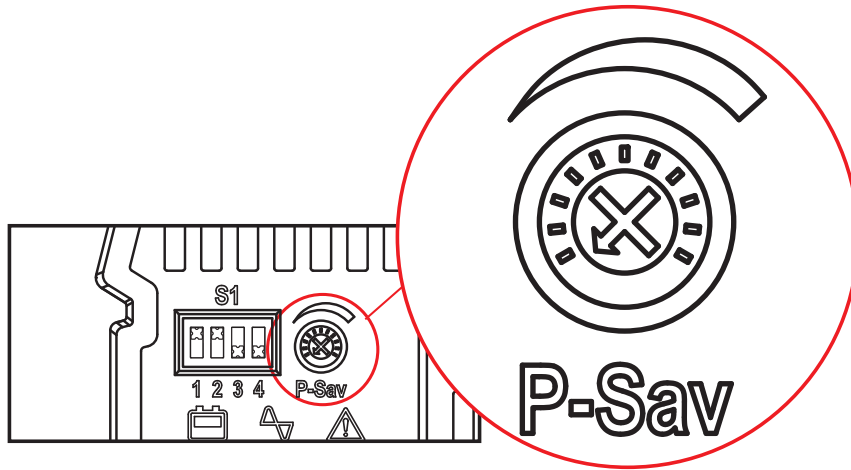
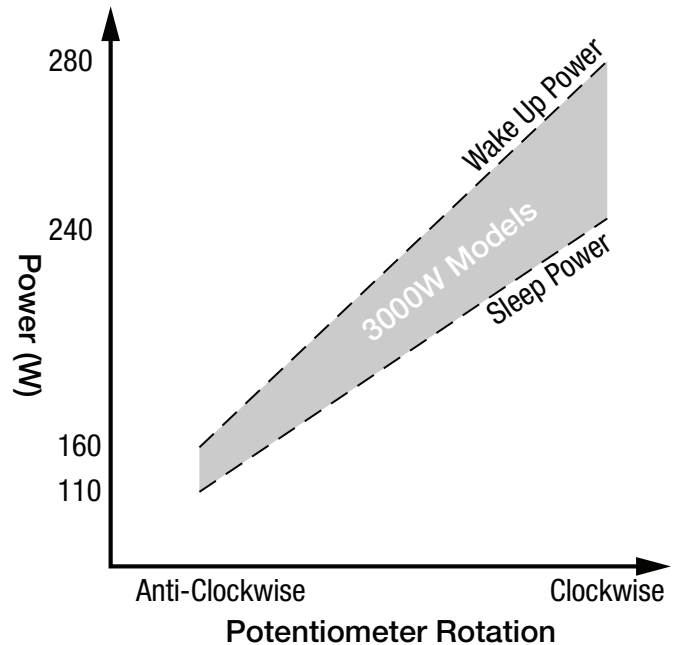
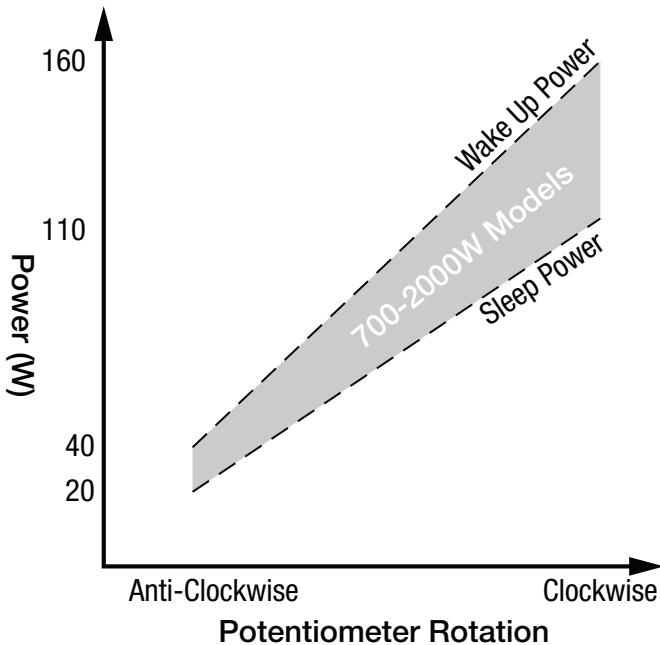

Figure 2.1.4.1 - Power Saving Load Adjustment

The user can adjust the potentiometer to set the input sleep and wake-up thresholds according to the load applied. The setting range is shown below:

Model	Minimum (Potentiometer turned fully anti-clockwise)		Maximum (Potentiometer turned fully clockwise)	
	Sleep Power	Wake Up Power	Sleep Power	Wake Up Power
700/1000/1500/2000W	<20W	>40W	<110W	>160W
3000W	<40W	>60W	<240W	>280W



2.1.5 TRC Port (RJ45) (E)

Not currently used.

2.1.6 AC Output Interface (F)

2.1.6.1 700/1000/1500/2000W Models

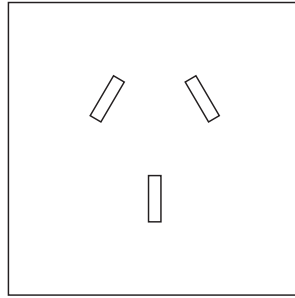

Figure 2.1.6.1 - Standard Australia / New Zealand 10A Socket

2.1.6.2 3000W Models

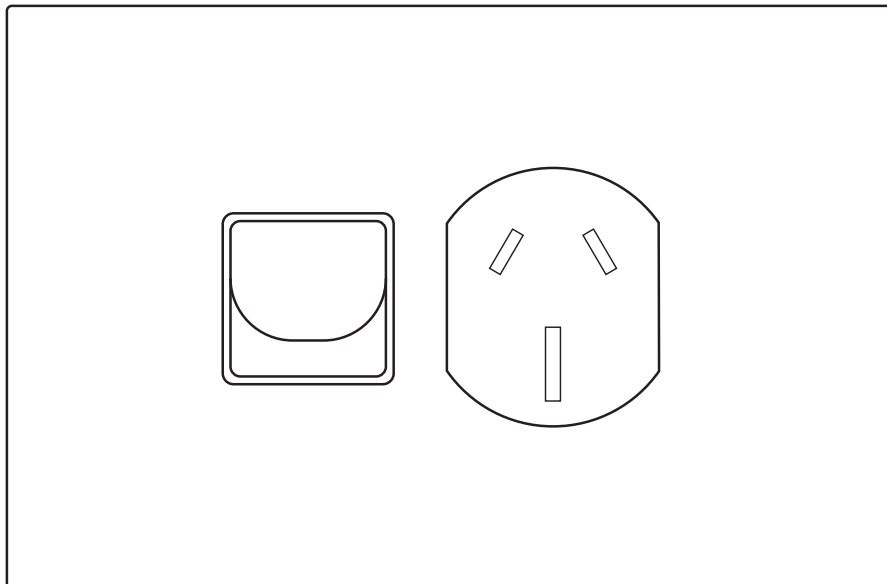

Figure 2.1.6.2 - Standard Australia / New Zealand 15A Socket

2.2 Rear Panel Operation

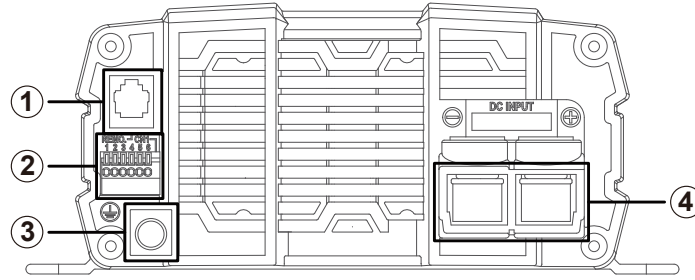

Figure 2.2.1 - 700/1000W Models

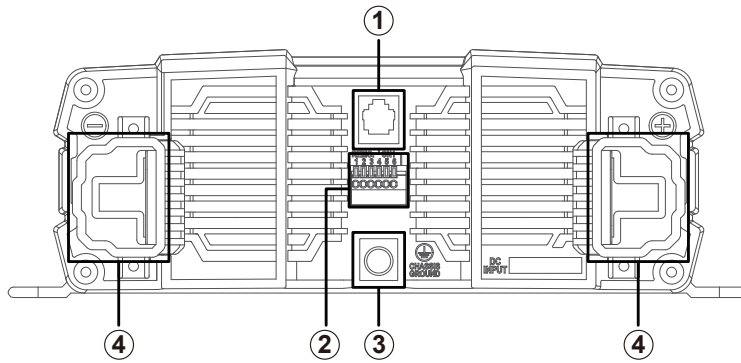

Figure 2.2.2 - 1500/2000W Models

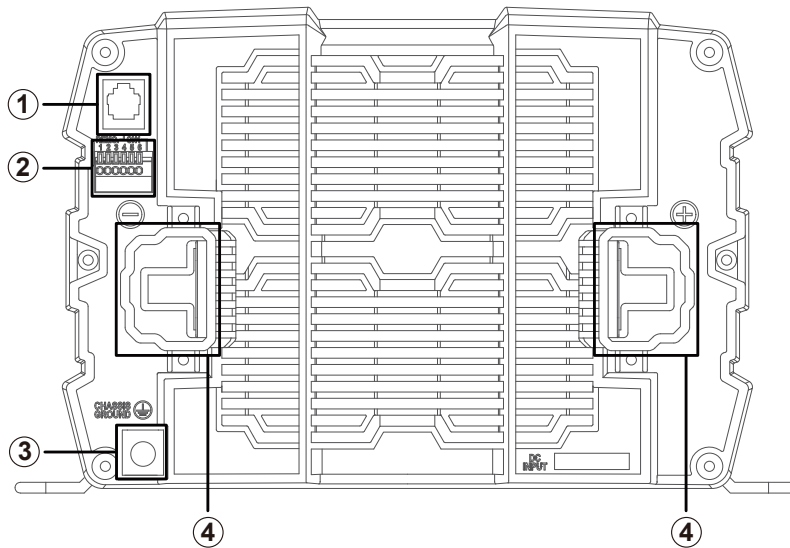

Figure 2.2.3 - 3000W Models

	700W	1000W	1500W	2000W	3000W
1	Remote Port (RJ11)				
2	Remote Control green terminal				
3	Chassis Ground				
4	DC Input Connector				

2.2.1 Remote Port (RJ11) ①

The RS Series inverter can be used with the REMOTE-RS remote controls via RS-232 communication. To enable use, the main switch on the inverter must be set to the “REMOTE” position.

Pin Number	Signal Description (1)	
1	Reserved	--
2	GND	Same Polarity as Battery Negative
3	RXD	RS232 RXD
4	TXD	RS232 TXD
5	RMT	Remote controller panel (positive)
6	VCC	Internal power for remote controller

2.2.2 Remote Control Green Terminal ②

The remote control green terminal is connected to a Form C relay for fault indication. When a fault occurs, the relay switches. Fault conditions include Input Under/Over voltage, output short-circuit/overload, Under/Over temperature.

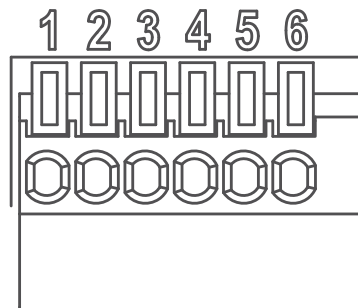

Figure 2.2.2.1 - Remote Control Terminal

Pin Number	Terminal Description
1	Fault relay, Normally Open (16V, 10mA max.)
2	Fault relay, Common (16V, 10mA max.)
3	Fault relay, Normal Closed (16V, 10mA max.)
4	Enable+ (ENB)
5	Enable- ($\overline{\text{ENB}}$)
6	Ground (Same polarity as battery negative)

NOTICE

- Before Installing - Make sure that the inverter main switch is at “OFF” position
- Before using the remote function, make sure the main switch is set to “REMOTE”
- Use 20-24AWG cable to connect the remote control terminals

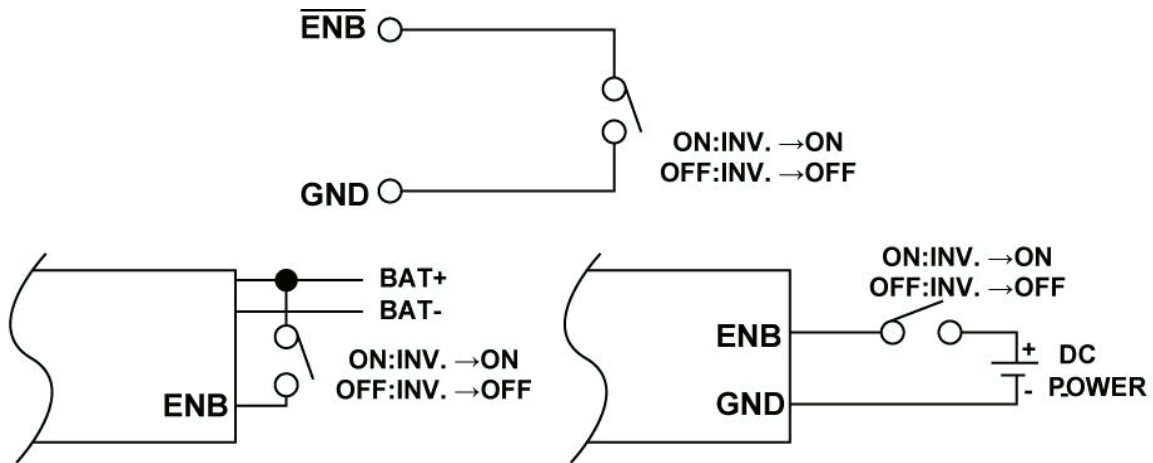

Figure 2.2.2.2 - Wiring configurations for Remote Control Green Terminal

2.2.3 Chassis Ground ③

The Chassis Ground terminal should be connected to the vehicle chassis using 8 B&S cable. This double insulated inverter is fully compliant with AS/NZS 4763 and is classified as an Isolated Inverter. The chassis ground connection is required but note that it is not a safety earth. Please refer to section 3.4 for important AC safety information.

2.2.4 DC Input Connection ④

Prior to installation:

- DC Supply cables should be as short as possible (no longer than the values shown in table 2.2.4.1 & 2.2.4.2)
- The size of the cable should be thick enough to maintain a voltage drop of less than 2% when carrying the maximum input current. This will help prevent frequent low-input voltage warnings and shutdown.
- The following sizes of cables and fuses are recommended for connection of the supply batteries to inverter, see table 2.2.4.1 & 2.2.4.2 over the page for suitable cable sizing for your installation.
- Ensure lugs suitable to the selected cable size and to the inverter terminals are used, refer to table 2.2.4.3 over the page for suitable lug size with reference to your chosen cable size.

Table 2.2.4.1 - Recommended Cable & Fuse Sizing (12V Install)

12V Inverter	700W	1000W	1500W	2000W	3000W
<i>Fuse Size (A)</i>	125	175	225	250	450
<i>Recommended Fuse</i>	Mega	Mega	Mega	Mega	Mega
Cable length	Cable Size mm² (AWG)				
0 - 1m	27 (3)	54 (0)	85 (000)	105 (0000)	120*
1 - 2m	27 (3)	54 (0)	85 (000)	105 (0000)	120*
2 - 3m	34 (2)	68 (00)	85 (000)	105 (0000)	x
3 - 4m	54 (0)	x	105 (0000)	120	x
4 - 5m	68 (00)	x	120	x	x
5 - 6m	x	x	x	x	x

Fuse ratings are suitable to these recommended minimum cable sizes.

* High temperature (110°C) or higher rated cable is required.

Table 2.2.4.2 - Recommended Cable & Fuse Sizing (24V Install)

24V Inverter	700W	1000W	1500W	2000W	3000W
<i>Fuse Size (A)</i>	50	70	100	150	225
<i>Recommended Fuse</i>	Midi	Midi	Midi	Midi/Mega	Mega
Cable length	Cable Size mm² (AWG)				
0 - 1m	8 (8)	13 (6)	21 (4)	34 (2)	85 (000)
1 - 2m	8 (8)	13 (6)	21 (4)	34 (2)	85 (000)
2 - 3m	13 (6)	13 (6)	21 (4)	34 (2)	85 (000)
3 - 4m	13 (6)	21 (4)	27 (3)	42 (2)	85 (000)
4 - 5m	21 (4)	27 (3)	34 (2)	54 (0)	85 (000)
5 - 6m	21 (4)	34 (2)	42 (1)	68 (00)	105 (0000)

Fuse ratings are suitable to these recommended cable sizes.

3 INSTALLATION

3.1 Mounting

The power inverter should be used in an environment that meets the following requirements:

1. Dry – Do not allow water to drip on or enter into the inverter.
2. Cool – Ambient air temperature should be between 0°C and 40°C, the cooler the better.
3. Safe – Do not install the inverter in a battery compartment or other areas where volatile fumes may exist, such as fuel storage areas or engine compartments.
4. Ventilated – Keep the inverter at a distance (at least 25mm) away from surrounding objects. Ensure the ventilation shafts on the rear and the bottom of the unit are not obstructed.
5. Dust – Do not install the inverter in a dusty environment where the dust can be inhaled into the unit when the cooling fan is working.
6. Fused – A fuse must be fitted between the battery and the inverter.
7. Close to batteries – Avoid excessive cable lengths however the unit should not be installed within 300mm or in the same compartment as a battery.
8. Use the recommended wire lengths and sizes (see section 2.2.4).
9. Do not mount the inverter where it will be exposed to the gasses produced by the battery. These gasses are very corrosive, and prolonged exposure will damage the inverter.

⚠ WARNING

RISK OF ELECTRICAL SHOCK. DO NOT EXPOSE THE INVERTER TO RAIN, SNOW, SPRAY, BILGE OR DUST. DOING SO MAY RESULT IN DAMAGE TO THE INVERTER OR OTHER APPLIANCES INSTALLED IN THE SYSTEM OR RESULT IN ELECTRIC SHOCK OR FIRE.

3.2 Ventilation Fan

The fan is load controlled and will engage when the AC Power Consumption reaches a certain level. Ensure that the fan is not obstructed and is at a distance of at least 25mm from surrounding objects.

NOTICE

Install the inverter in a well-ventilated area with reasonable clearance. Do not install the inverter in a zero-clearance compartment or obstruct the ventilation openings. Doing so may result in the inverter overheating and ultimately damage the inverter.

3 INSTALLATION

3.3 DC Wiring Connections

⚠ WARNING

RISK OF ELECTRICAL SHOCK. BEFORE PROCEEDING, CAREFULLY CHECK THAT THE INVERTER IS NOT CONNECTED TO ANY BATTERIES AND THAT ALL WIRING IS DISCONNECTED FROM ANY ELECTRICAL SOURCES. DO NOT CONNECT THE OUTPUT TERMINALS OF THE INVERTER TO AN INCOMING AC SOURCE.

DC supply cables should be kept as short as possible whilst still adhering to the above installation requirements (ideally less than 1.8m / 6ft). Cables should be of an adequate size to handle the required currents.

Cables which are not of adequate size (too thin) will result in Voltage drop and poor performance of the inverter (such as poor surge capability, low-input voltage warnings and shutdowns). As the supply cable increases in length or reduces in size (gets narrower) the voltage drop will increase.

⚠ CAUTION

Batteries are capable of providing very large currents in the case of a short circuit. A fuse must be installed on the positive supply cable as close as practical to the battery. Failure to do so provides inadequate protection against fire in the case of a short circuit. Only use high quality copper cable and keep the cable length short, refer to section 2.2.4 for more information.

NOTICE

Reverse polarity connection will blow the internal fuse and may cause permanent damage to the inverter.

Before making the DC wiring connections, the main switch **(A)** (page 12) must be set to “OFF”. Connect the DC input terminals to an appropriate battery supply or other DC power source. Power source [+] is positive and [-] is negative.

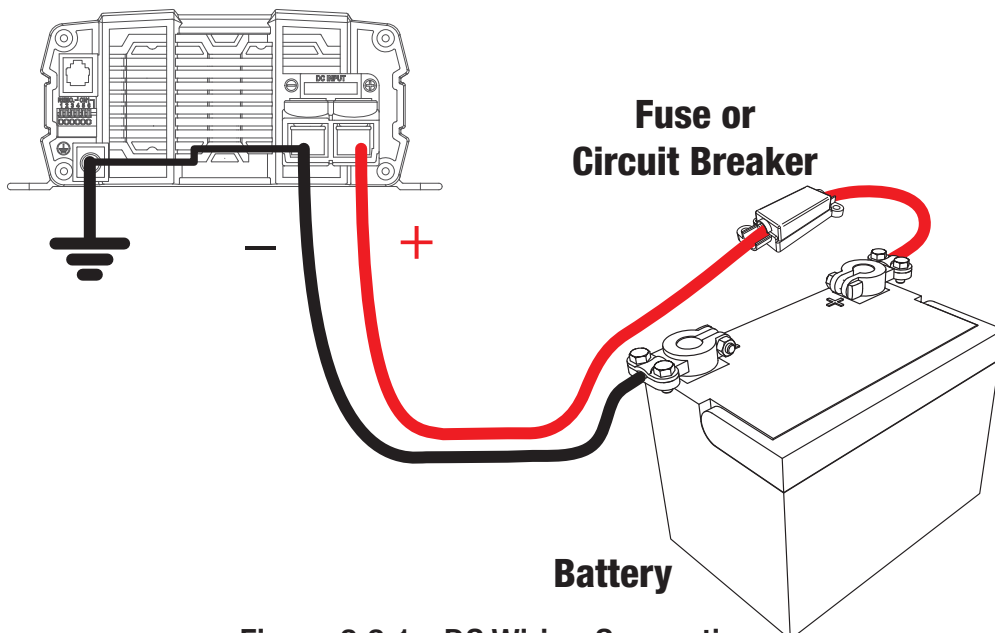

Figure 3.3.1 - DC Wiring Connections

⚠ CAUTION

Ensure that all the DC connections are tight - torque to 11.7-13Nm (9-10 ft-lbs). Loose connections could result in overheating and can be a potential hazard.

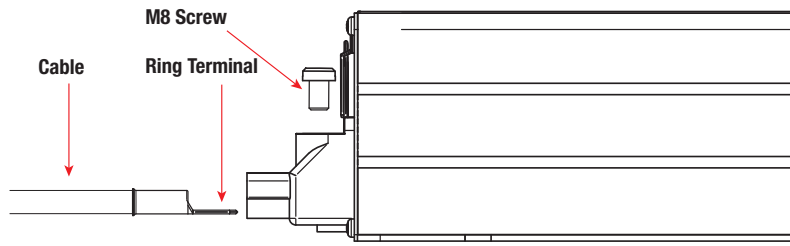

Figure 3.3.2 - 700/1000W Models

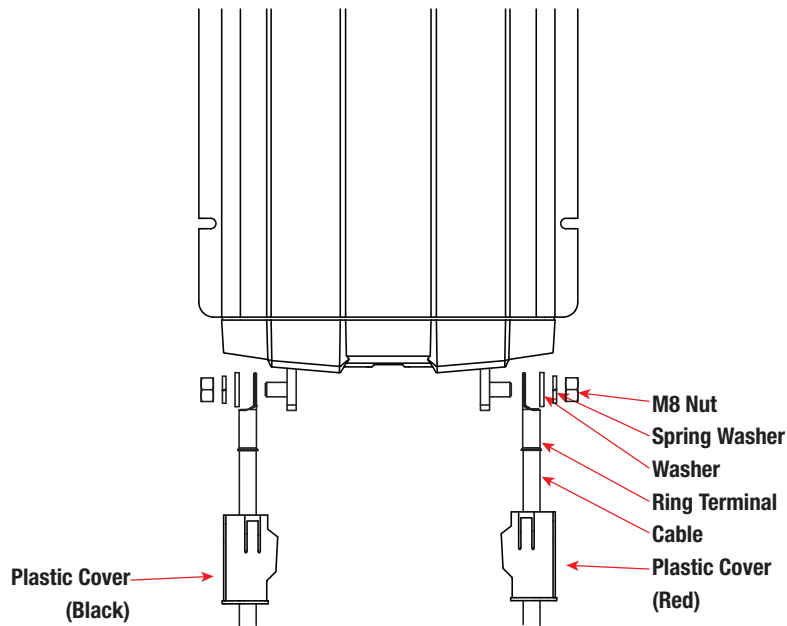

Figure 3.3.3 - 1500W/2000W/3000W Models

⚠ CAUTION

Do not operate the inverter with damaged or substandard wiring. Selecting the wrong cable or fuse size could result in harm to the installer or user and/or damage to the inverter or other appliances installed in the system. The installer is responsible for ensuring that the correct cable and fuse sizes are used when installing this inverter. Refer to section 2.2.4 for more information.

3 INSTALLATION

3.4 AC Safety Grounding

NOTICE

This inverter is isolated in accordance with AS/NZS 4763 and does not normally require RCD protection. The AC output active and neutral are isolated from the DC Input Supply and Chassis Earth by double insulation. The output earth pin is not connected to ground, it is floating.

If for any reason an RCD is required it should be fitted by a licensed electrician. External connection of neutral and chassis earth should be determined as appropriate or not by the licensed electrician on the specific case by case basis.

Residual Current Devices (RCD)

Certain installation codes and/or government regulations requiring the installation of an RCD must be done by a licensed electrician.

3.5 Maintenance

Very little maintenance is required to keep the inverter operating correctly. The exterior of the inverter should be cleaned periodically with a damp cloth to prevent accumulation of dust and dirt. At the same time, tighten the screws on the DC input terminals. Turn the unit OFF before cleaning.

4 TWO YEAR PRODUCT WARRANTY

Over the last three decades our company has established a reputation as the power conversion specialist.

A 100% Australian-owned company, we have met the needs of customers in transport and other industries through exciting, innovative thinking.

We believe in total customer satisfaction and practice this by offering our customers:

- Technical advice free of jargon and free of charge
- Prompt turnaround of orders throughout Australia and globally
- Friendly, personalised, professional service and product support

In the unlikely event that a technical issue arises with a REDARC product, customers are encouraged to initially contact the REDARC Technical Support Team on (08) 8322 4848 or power@redarc.com.au for prompt and efficient diagnosis and product support.

Our goods come with guarantees that cannot be excluded under the Australian Consumer Law. You are entitled to a replacement or refund for a major failure and compensation for any other reasonably foreseeable loss or damage. You are also entitled to have the goods repaired or replaced if the goods fail to be of acceptable quality and the failure does not amount to a major failure.

The benefits of this Warranty are in addition to other rights and remedies available at law in respect of the Products and shall not derogate from any applicable mandatory statutory provisions or rights under the Australian Consumer Law.

REDARC Electronics Pty Ltd at the REDARC Trust trading as REDARC Electronics ("REDARC") offers a warranty in respect of its Products where the Products are purchased from an authorised distributor or reseller of REDARC by a person ("Purchaser"), on the terms and conditions, and for the duration, outlined below in this document ("Warranty").

1. In this Warranty, the term **Products** means:
 - 1.1 all products manufactured or supplied by REDARC (excluding its solar products which are covered by REDARC's Solar Product Warranty); and
 - 1.2 any component of or accessory for any product in clause 1.1 manufactured or supplied by REDARC.

Offer and duration of product warranties

2. REDARC warrants that its Products will be free, under normal application, installation, use and service conditions, from defects in materials and workmanship affecting normal use, for **2 years** from the date of purchase (**Warranty Period**).
3. Where a Product malfunctions or becomes inoperative during the Warranty Period, due to a defect in materials or workmanship, as determined by REDARC, then subject to further rights conferred by the Australian Consumer Law on the Purchaser, REDARC will, in exercise of its sole discretion, either:
 - 3.1 repair the defective Product;
 - 3.2 replace the defective Product; or
 - 3.3 provide a refund to the Purchaser for the purchase price paid for the defective Product,without charge to the Purchaser.
4. The warranty given by REDARC in clause 3 covers the reasonable costs of delivery and installation of any repaired or replaced Products or components of Products to the Purchaser's usual residential address notified to REDARC, together with the reasonable costs of removal and return of any Products determined by REDARC to be defective.
5. If the Purchaser incurs expenses of the nature referred to in clause 4 in the context of making a claim pursuant to this Warranty that is accepted by REDARC, the Purchaser will be entitled to claim for reimbursement of those expenses which REDARC determines, in exercise of its sole discretion, to be reasonably incurred, provided that the claim is notified to REDARC in writing at the postal address or email address specified in clause 21 and includes:
 - 5.1 details of the relevant expenses incurred by the Purchaser; and
 - 5.2 proof of the relevant expenses having been incurred by the Purchaser.

Exclusions and limitations

6. This Warranty will not apply to, or include any defect, damage, fault, failure or malfunction of a Product, which REDARC determines, in exercise of its sole discretion, to be due to:
 - 6.1 normal wear and tear or exposure to weather conditions over time;
 - 6.2 accident, misuse, abuse, negligence, vandalism, alteration or modification;
 - 6.3 non-observance of any of the instructions supplied by REDARC, including instructions concerning installation, configuring, connecting, commissioning, use or application of the Product, including without limitation choice of location;
 - 6.4 failure to ensure proper maintenance of the Product strictly in accordance with REDARC's instructions or failure to ensure proper maintenance of any associated appliances or machinery;
 - 6.5 repairs to the Product that are not strictly in accordance with REDARC's instructions;
 - 6.6 installation, repairs or maintenance of the Product by, or under the supervision of, a person who is not a qualified auto electrician or technician, or if non-genuine or non-approved parts have been fitted;
 - 6.7 faulty power supply, power failure, electrical spikes or surges, lightning, flood, storm, hail, extreme heat, fire or other occurrence outside the control of REDARC;
 - 6.8 use other than for any reasonable purpose for which the Product was manufactured;
 - 6.9 any indirect or incidental damage of whatever nature outside the control of REDARC.
7. Warranty claims in respect of a Product must be made in writing to REDARC at the postal address or email address specified in clause 21 within the Warranty Period. Such claims must include the following:
 - 7.1 details of the alleged defect or fault and the circumstances surrounding the defect or fault;
 - 7.2 evidence of the claim, including photographs of the Product (where the subject of the claim is capable of being photographed);
 - 7.3 the serial number of the Product, specified on the label affixed to the Product; and
 - 7.4 proof of purchase documentation for the Product from an authorised distributor or reseller of REDARC, which clearly shows the date and place of purchase.The return of any Products without the prior written instructions of REDARC will not be accepted by REDARC.

8. Without limiting any other clause in this Warranty, REDARC has the right to reject any Warranty claim made by a Purchaser pursuant to this Warranty where:
 - 8.1 the Purchaser does not notify REDARC in writing of a Warranty claim within the Warranty Period;
 - 8.2 the Purchaser does not notify REDARC in writing of a Warranty claim within 1 month of becoming aware of the relevant circumstances giving rise to the claim, so that any further problems with the Product are minimised;
 - 8.3 the serial number of the Product has been altered, removed or made illegible without the written authority of REDARC;
 - 8.4 the Purchaser is unable to provide proof of purchase documentation in accordance with clause 7.4 or evidence that the Product was properly installed and removed (if relevant), and that proper maintenance has been performed on the Product, by, or under the supervision of, a qualified auto electrician or technician, in accordance with the instructions of REDARC.
9. If the Product is found to be working satisfactorily on return to REDARC or upon investigation by REDARC, the Purchaser must pay REDARC's reasonable costs of testing and investigating the Product in addition to shipping and transportation charges. Where REDARC is in possession of the Product, the Product will be returned to the Purchaser on receipt of the amount charged.
10. Any replaced Products or components of Products shall become the property of REDARC.
11. REDARC may, in exercise of its sole discretion, deliver another type of Product or component of a Product (different in size, colour, shape, weight, brand and/or other specifications) in fulfilling its obligations under this Warranty, in the event that REDARC has discontinued manufacturing or supplying the relevant Product or component at the time of the Warranty claim, or where such Product or component is superior to that originally purchased by the Purchaser.

Other conditions of Warranty

12. If the Purchaser acquired a Product for the purpose of resupply, then this Warranty shall not apply to that Product.
13. In particular, the sale of a Product via an online auction, online store or other internet website by a party that is not an authorised distributor or reseller of the Product will be deemed to be a resupply within the meaning of the Australian Consumer Law and will render this Warranty void, as REDARC has no control over the storage, handling, quality or safety of Products sold by such persons.
14. A Purchaser shall only be entitled to the benefit of this Warranty after all amounts owing in respect of the Product have been paid.
15. While REDARC warrants that the Products will be free from defects in materials and workmanship in the circumstances set out in this Warranty, to the maximum extent permitted by law REDARC does not warrant that the operation of the Products will be uninterrupted or error-free.
16. To the maximum extent permitted by law, REDARC's determination of the existence of any defect and the cause of any defect will be conclusive.
17. Spare parts or materials for the Products are guaranteed to be available for a period of at least 2 years after purchase of the Products.
18. The agents, officers and employees of any distributor or reseller of the Products and of REDARC are not authorised to vary or extend the terms of this Warranty.
19. REDARC shall not be responsible or liable to the Customer or any third party in connection with any non-performance or delay in performance of any terms and conditions of this Warranty, due to acts of God, war, riots, strikes, warlike conditions, plague or other epidemic, fire, flood, blizzard, hurricane, changes of public policies, terrorism and other events which are beyond the control of REDARC. In such circumstances, REDARC may suspend performance of this Warranty without liability for the period of the delay reasonably attributable to such causes.
20. If a clause or part of a clause in this Warranty can be read in a way that makes it illegal, unenforceable or invalid, but can also be read in a way that makes it legal, enforceable and valid, it must be read in the latter way. If any clause or part of a clause in this Warranty is illegal, unenforceable or invalid, that clause or part is to be treated as removed from this Warranty, but the rest of this Warranty is not affected.

REDARC's contact details

21. REDARC's contact details for the sending of Warranty claims under this Warranty are:

REDARC Electronics Pty Ltd
23 Brodie Road (North), Lonsdale SA 5160
Email: power@redarc.com.au
Telephone: +61 8 8322 4848

THE POWER OF
REDARC®

Free technical assistance!

please contact

REDARC Electronics

23 Brodie Road North, Lonsdale SA

(08) 8322 4848

power@redarc.com.au

www.redarc.com.au

Copyright © 2017 REDARC Electronics Pty Ltd. All rights reserved.

MADE IN TAIWAN