

XO Series Jockey Wheel

December 1, 2014

ASSEMBLY & MOUNTING

Place the jockey wheel on the trailer draw-bar as near to the coupling as convenient. Make sure that the jockey wheel does not interfere with other parts of the trailer or vehicle.

Tighten all bolts evenly.

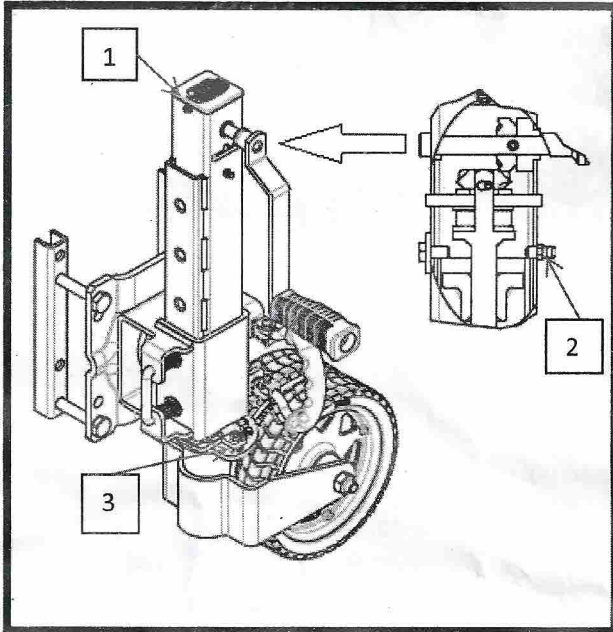

NOTE: This jockey wheel fits 75mm, 100mm, 130mm & 150mm rectangular drawbars up to 50mm wide. Drawbars wider than 50mm require replacement of existing mounting bolts with bolts of appropriate length.

OPERATION

Cranking can be minimized by adjusting the jockey wheel to the desired height. Be certain the yoke locking pin(3) is disengaged before cranking the handle to raise or lower the trailer. Raise trailer by cranking the jockey wheel anti-clockwise and lower by cranking clockwise.

When the jockey wheel reaches the end of its travel do not force handle. To do so will result in damage. When manoeuvring your trailer with weight on the jockey wheel, keep the jockey wheel cranked to the lowest possible position to avoid unnecessary strain. Before towing the trailer, be sure jockey wheel is raised completely and wheel locked in a position to give maximum road clearance.

CAUTION! - Loads in excess of rated capacity will cause accelerated wear on the jockey wheel parts and possible failure.

CAUTION! - This jockey wheel is not for highway use, never tow trailer with a load on the jockey wheel.

CAUTION! - Avoid cranking jockey wheel to unnecessary height and avoid side loads on jockey wheel that could cause damage or excessive wear.

MAINTENANCE

Minimal maintenance is required to keep your jockey wheel looking new and in good working order. Protect the finish by keeping it clean and periodically applying a coating of silicone lubricant spray. Lubrication is needed if the jockey wheel ever feels rough or produces a grinding noise when cranked. With weight off the jockey wheel remove plastic cap (1) by removing cap retaining screw. Place a sufficient amount of grease on the bevel gears, crank jockey wheel handle to ensure an even amount of grease is distributed on the bevel gears. Replace plastic cap (1) and insert cap retaining screw. Using a grease gun, fill a sufficient amount of grease into the inner shaft of the jockey wheel through the grease nipple (2) located behind the crank handle. Crank the handle in a clockwise direction lowering the jockey wheel, this will distribute the grease and work the grease along the entire thread.

NOTE: If this jockey wheel is fitted to a boat trailer or off road trailer that is subjected to constant immersion into salt water or water crossings then maintenance should be carried out more periodically.



Ark Corporation – 8 Smoothy Place, Arndell Pk, NSW 2148
W - www.arkcorp.com.au E - sales@arkcorporation.com

ASSEMBLING XO JOCKEY WHEEL FROM FLAT PACK:

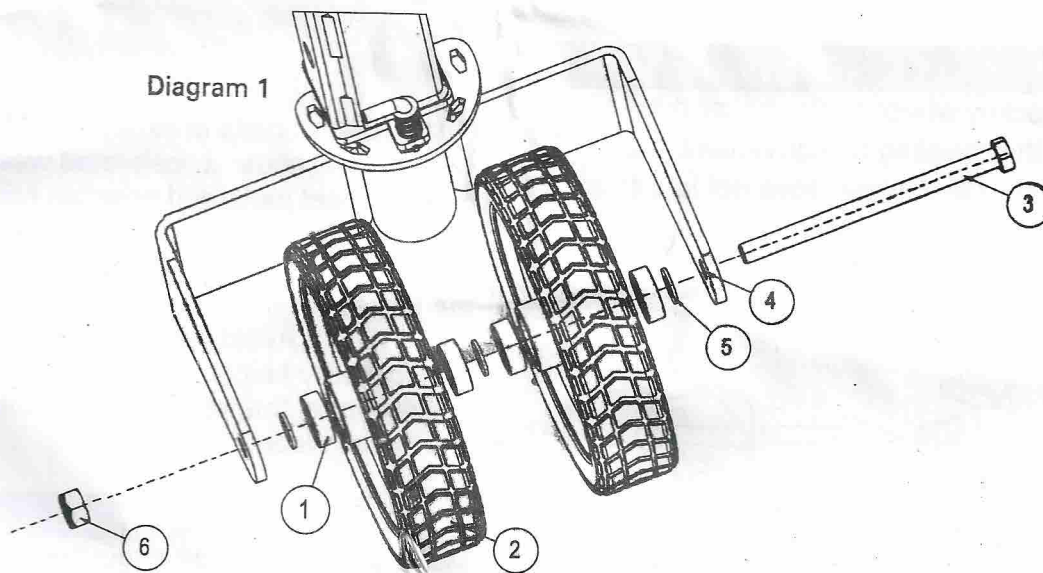

Step 1 – Insert one bearing (1) into each side of each wheel (2)

Step 2 – Thread the bolt (3) through one of the holes of the yoke (4)

Step 3 – Place one washer (5) onto the bolt (3) then a wheel - fitted with a bearing, while pushing the bolt through gradually as you add parts

Step 4 – Place another washer for the center position followed by the second wheel - fitted with a bearing, onto the bolt

Step 5 – Place the last washer onto the bolt and thread the bolt all the way through the yoke's hole

Step 6 – Secure the bolt and wheel mechanism with the nylock nut (6) provided but do not overtighten, ensure the wheels rotate freely.

DRAW BAR OBSTRUCTION(S):

In the event that there is an obstruction on your draw bar that prevents the bolt being fitted from the direction (A) shown, it is OK to insert the bolt from the opposite side (B) of the yoke.

